

Photochemical Steady State

With the Light On – For Rapid Deactivation, a Photochemical Process Reaches a Steady-State:

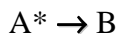

$$\frac{d[B]}{dt} = k_R [A^*]$$

$$J_a = j_{A^*} [A]$$

$$\Phi_B = \frac{d[B]/dt}{J_a}$$

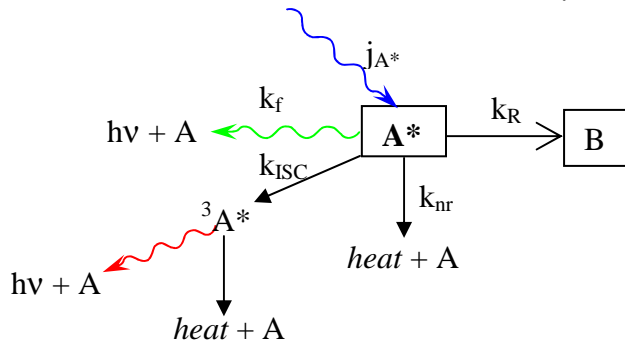

$$\frac{d[A^*]}{dt} = j_{A^*} [A] - k_f [A^*] - k_{ISC} [A^*] - k_{nr} [A^*] - k_R [A^*]$$

$$[A^*] = \frac{j_{A^*} [A]}{k_f + k_{ISC} + k_{nr} + k_R}$$

$$\frac{d[B]}{dt} = k_R [A^*] = \frac{k_R j_{A^*} [A]}{k_f + k_{ISC} + k_{nr} + k_R}$$

$$\Phi_B = \frac{d[B]/dt}{J_a} = \frac{k_R}{k_f + k_{ISC} + k_{nr} + k_R}$$

Fluorescence Quantum Yield -- Stern-Volmer Quenching:

$$J_f = k_f [A^*] \quad \Phi_f = J_f/J_a = \frac{k_f}{k_f + k_{ISC} + k_{nr} + k_R}$$



$$\Phi_f = J_f/J_a = \frac{k_f}{k_f + k_{ISC} + k_{nr} + k_q [Q]} \quad \Phi_o = \frac{k_f}{k_f + k_{ISC} + k_{nr}}$$

$$\Phi_o/\Phi_f = \frac{k_f + k_{ISC} + k_{nr} + k_q [Q]}{k_f + k_{ISC} + k_{nr}} = 1 + \frac{k_q [Q]}{k_f + k_{ISC} + k_{nr}}$$

With the Light Off: First-Order Competitive Processes Deactivate the Excited State:

$$\frac{d[A^*]}{dt} = -k_f [A^*] - k_{ISC} [A^*] - k_{nr} [A^*] - k_R [A^*]$$

$$[A^*] = [A^*]_o e^{-(k_f + k_{ISC} + k_{nr} + k_R) t}$$

$$\frac{1}{\tau} = k_f + k_{ISC} + k_{nr} + k_R = \frac{1}{\tau_f} + \frac{1}{\tau_{ISC}} + \frac{1}{\tau_{nr}} + \frac{1}{\tau_R}$$

$$J_f = k_f [A^*] = k_f [A^*]_o e^{-(k_f + k_{ISC} + k_{nr} + k_R) t} = k_f [A^*]_o e^{-t/\tau}$$